

ROTATOR HR16SM

Specially designed for the Harvester heads

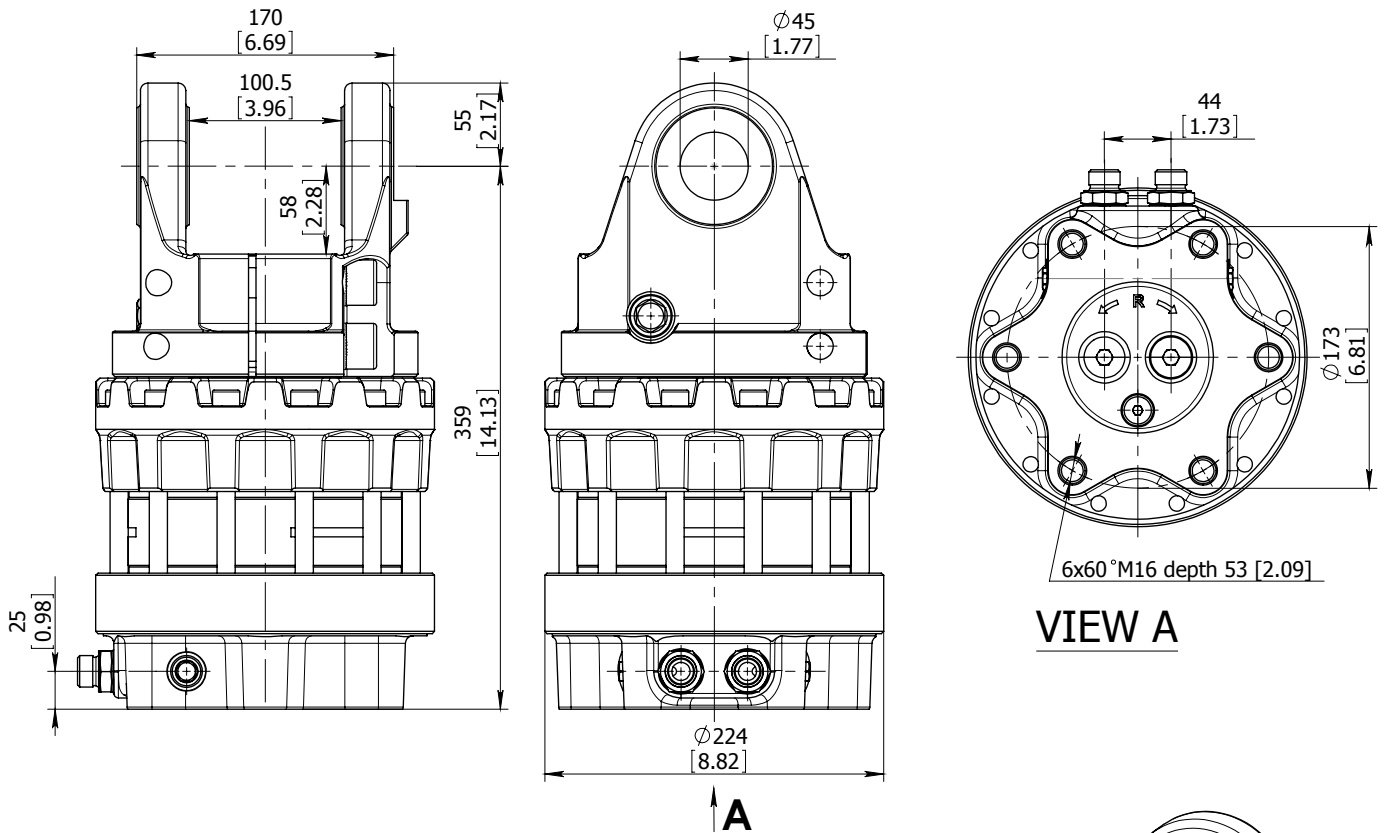

Technical data

Rotation	Unlimited
Max axial load static, kN (lbf)	+160 (35976)
	-100 (22485)
Max axial load dynamic, kN (lbf)	+80 (17988)
	-50 (11242)
Torque at 25MPa (3625psi), Nm (lb ft)	3300 (2434)
Rec oilflow, l/min (US gallon)	40 (10.6)
Weight, kg (lb)	71 (157)

Max working pressure:

Rotator ←R→ Max 25 MPa (3625 psi)*

Connection:

G 1/2"

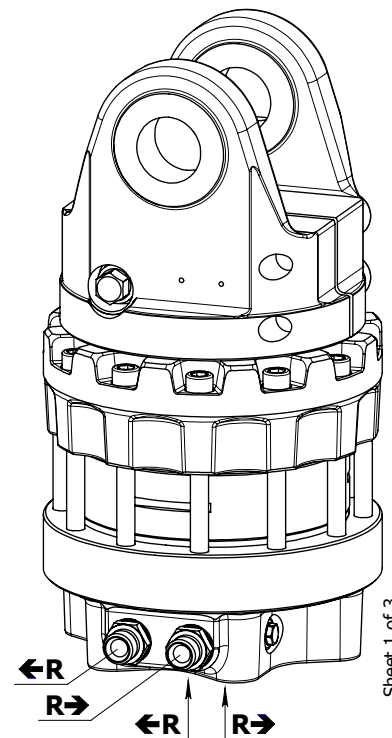

* Relief valves fitted