

ROTATOR HR12SM

Specially designed for the Harvester heads

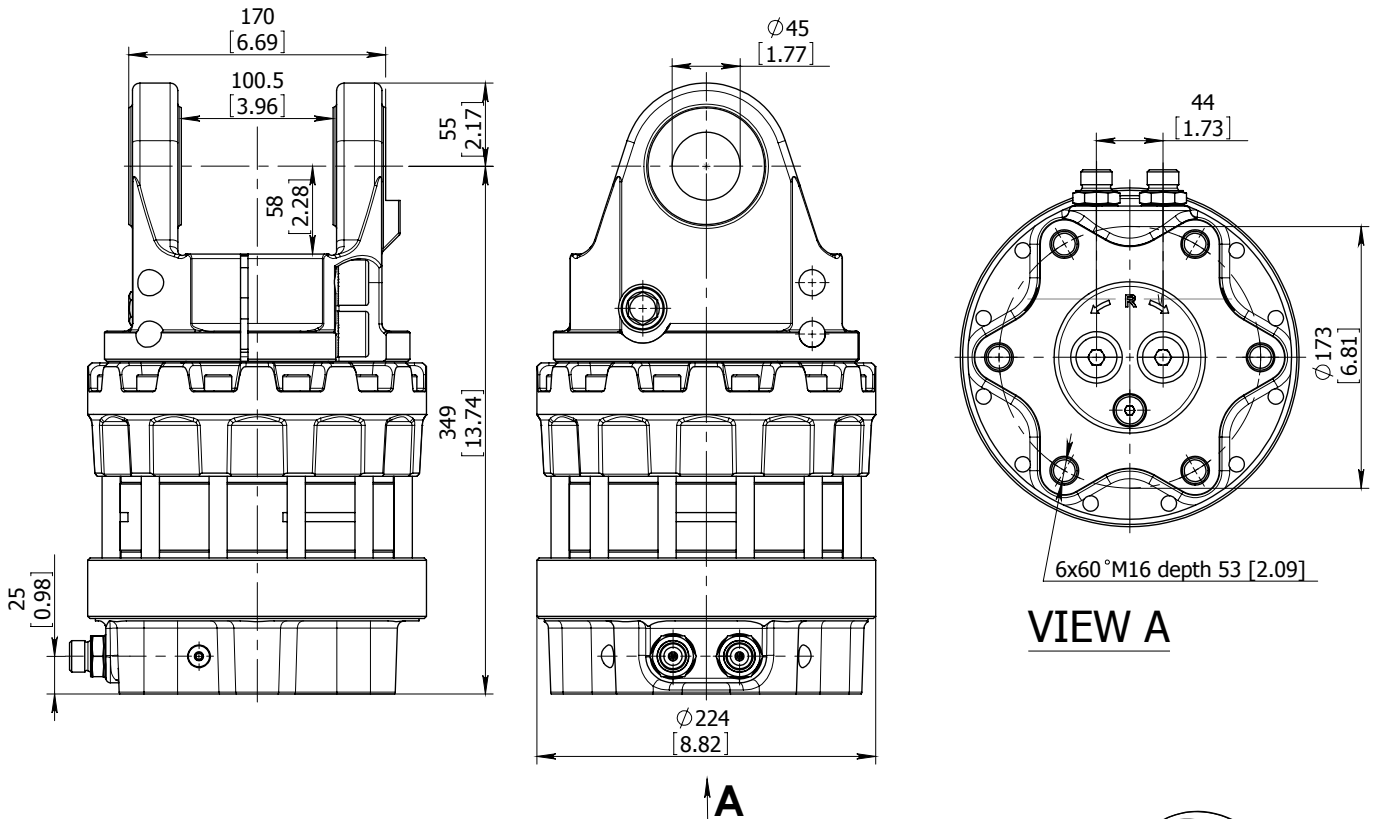

Technical data

Rotation	Unlimited
Max axial load static, kN (lbf)	+120 (26982)
	-100 (22485)
Max axial load dynamic, kN (lbf)	+60 (13491)
	-50 (11242)
Torque at 25MPa (3625psi), Nm (lb ft)	2900 (2139)
Rec oilflow, l/min (US gallon)	35 (9.25)
Weight, kg (lb)	69 (152)

Max working pressure:

Rotator ←R→ Max 25 MPa (3625 psi)

Connection:

G 1/2"

