

ROTATOR HR10SM

Specially designed for the Harvester heads

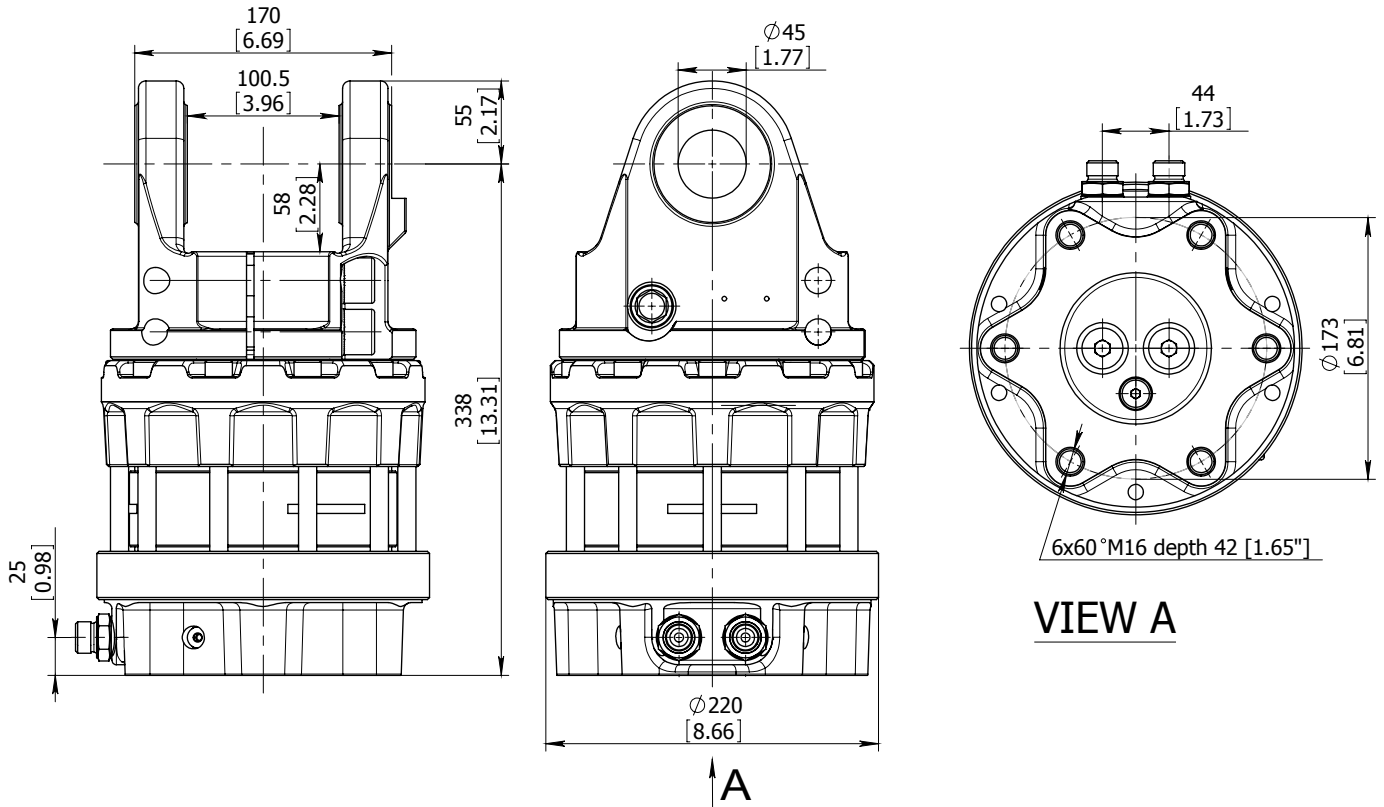

Technical data

Rotation	Unlimited
Max axial load static, kN (lbf)	+100 (22485) - 90 (20236)
Max axial load dynamic, kN (lbf)	+50 (11242) - 45 (10118)
Torque at 25MPa (3625psi), Nm (lb ft)	2400 (1770)
Rec oilflow, l/min (US gallon)	30 (7.9)
Weight, kg (lb)	64 (140)

Max working pressure:

Rotator **←R→** Max 25 MPa (3625 psi)

Connection:

G 1/2"

